

Centre for Science & Environment builds a world class training academy cooled with HMX's eco-friendly solutions

Background

The Centre for Science and Environment (CSE) is a not-for-profit public research and advocacy organisation which is a leading think tank on environment and development issues. CSE has set up an education and training institute, the Anil Agarwal Environment Training Institute (AAETI) at Alwar, Rajasthan, which offers a range of environmental training programmes. AAETI's learning and training facilities include several classrooms, seminar and conference rooms, together with dining halls and rooms for overnight stays.

Challenges

CSE desired AAETI to be a world-class complex running on sustainable solutions that showcase its commitment to the environment. CSE also wished to provide its students, faculty, staff and visitors comfortable ambient conditions at all times.

However, right from the design phase, CSE was loath to consider conventional air-conditioning systems because of their high energy consumption (energy consumption in buildings with air conditioning in India is between 35-45% of India's total power consumed). Additionally, air-conditioners use refrigerants which release CFCs and in turn deplete the ozone layer.

Solution

CSE approached HMX for a suitable solution and recommended the use of IDEC (Indirect Direct Evaporative Cooling) and hybrid air-conditioning systems. HMX's cooling solutions constituted a major portion of the MEP (mechanical, electrical and plumbing) design in AAETI.

Indirect Direct Evaporative Cooling: With Indirect Direct Evaporative Cooling (IDEC), the incoming air stream is first cooled with Indirect Evaporative Cooling (IEC) and then further cooled with Direct Evaporative Cooling (DEC).

IDEC systems are an excellent upgrade over conventional air coolers. IDEC delivers 4-5°C lower temperatures and adds up to 60% less moisture as compared to air coolers. IDEC is also an energy efficient alternative to conventional air-conditioning systems as IDEC consumes up to 60% less power.

Hybrid Air-Conditioning: While the IDEC solution is ideal for most of the weather in Alwar around the year, it may fall short of maintaining comfort during the monsoon season due to the lower wet bulb depression at that time of the year.

HMX's hybrid air-conditioning system brings together the best of both worlds – Indirect Direct Evaporative Cooling and refrigerated air-conditioning, thus providing comfort in all seasons. For most of the year, the hybrid air conditioner runs in IDEC only mode. For some part of the year, it runs in air conditioner mode.

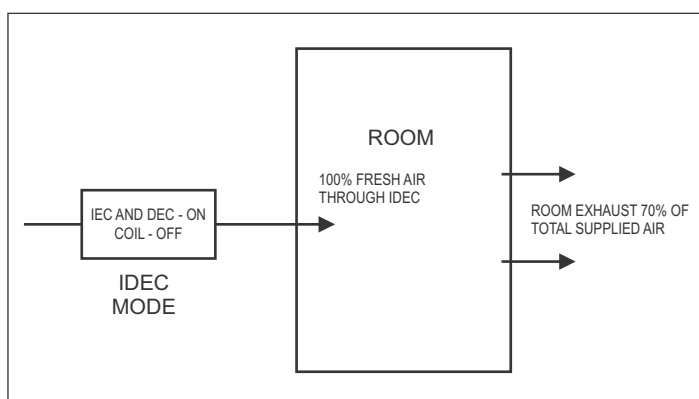

Schematic of an IDEC system

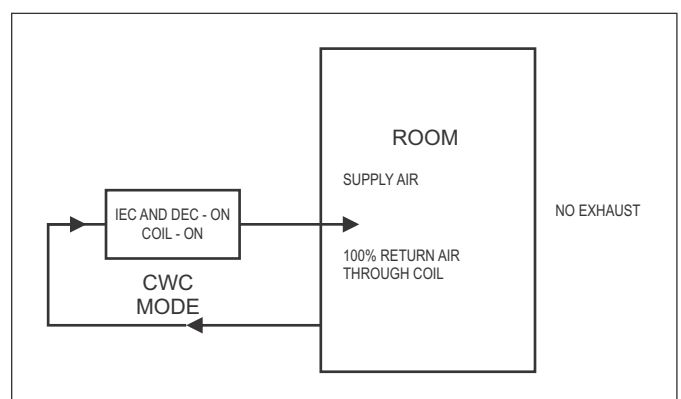

Schematic of hybrid air-conditioning system

AAETI decided to go with HMX's recommendation and accordingly the following systems were installed:

Sr. No.	Block	Machine installed	Capacity (CFM)
1	Academic block (Classroom 3 & 4)	Hybrid air-conditioning	12,500 CFM
2	Academic block (Classroom 1,2 & 5)	Hybrid air-conditioning	15,000 CFM
3	Housing staff 1 (Basement, 1st & 2nd Floor)	Hybrid air-conditioning	15,000 CFM
4	Housing staff 1 (3rd & 4th Floor)	Hybrid air-conditioning	12,000 CFM
5	Housing staff 2 (All floors)	Hybrid air-conditioning	12,000 CFM
6	Services (All floors)	Indirect Direct Evaporative Cooling	13,000 CFM
7	Canteen	Indirect Direct Evaporative Cooling	13,500 CFM

*Cubic Feet per Minute

Result

AAETI has left no stone unturned in creating a world class facility with notable green features like an energy-saving architectural design, rainwater harvesting systems, a decentralised wastewater treatment system and HMX cooling solutions.

AAETI is very happy with the performance of the HMX cooling solutions, which not only provide the required level of comfort, but also contribute to substantial energy savings in the institute.



Canteen and housing facility



Machine installed at AAETI