



GOLLER - DESIZA

GOLLER - COMPLEXA

Modular Pretreatment

GOLLER - COMPLEXA

Modular Pretreatment of Woven Fabrics

2

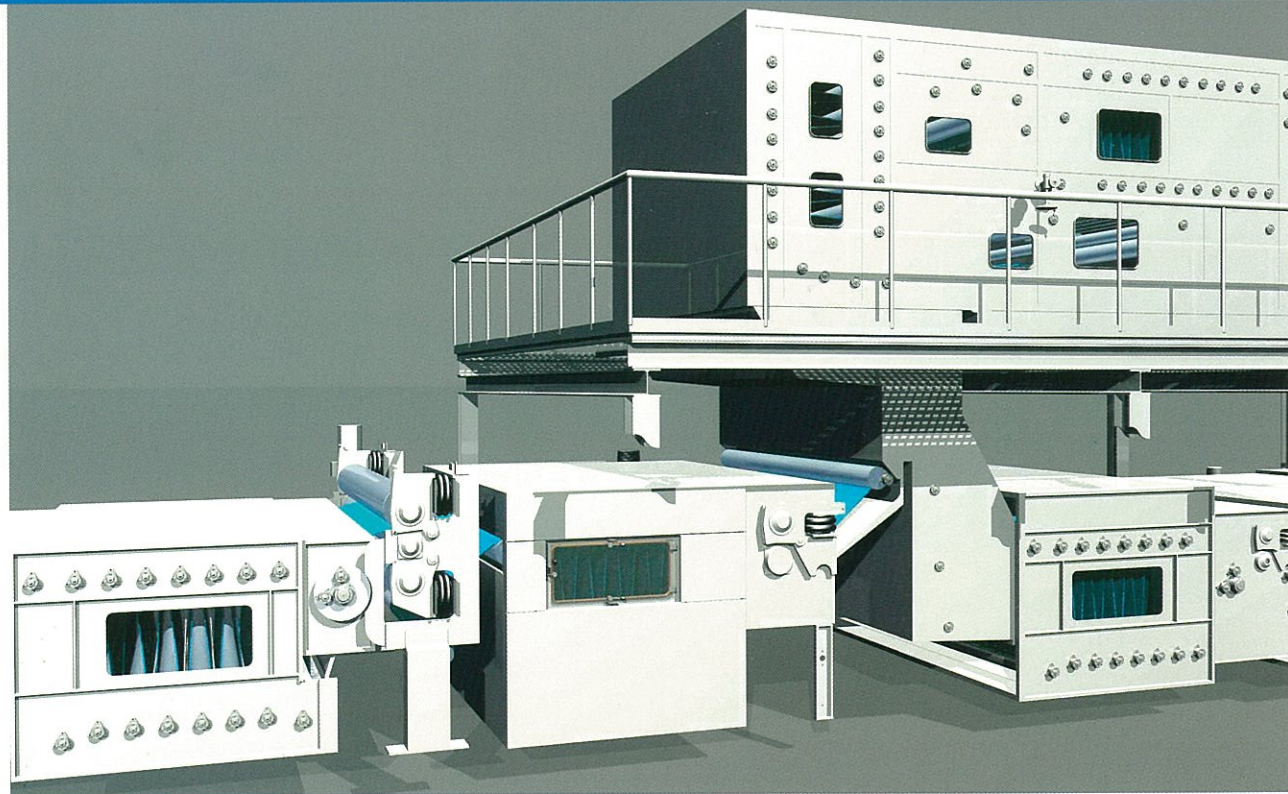

Natural fibres processing

- One or two step scouring and bleaching with a high degree of whiteness
- Complete degradation of seeds and removal of fibre accompanying substances
- Outstanding and constant absorbency
- Low fibre-damage
- Improved hand of the fabric
- Reproducibility of finishing results
- High efficiency
- Short amortisation time

Advantages

- Tailored to your requirements
- Modular system with first class components
- Long lasting and economic service life
- High quality material solidly engineered
- With PC-control and recipe administration

- Water flow dependent on fabric weight
- Counterflow between final washing and pre-washing
- Precise temperature regulation
- Even and precise temperature distribution in the bath with thermplate heating
- Heat recovery system
- Chemical dosing proportional to the fabric weight
- pH-value-regulation
- Remote control via modem

Working width	up to 3400 mm
Roller width	up to 3600 mm
Fabric speed	up to 200 m/min
Fabric content of rollerbed	up to 2500 m
Reaction time	up to 40 min
Tight strand passage	30–150 m
Processes	desizing, demineralizing scouring, bleaching

3



Schema COMPLEXA

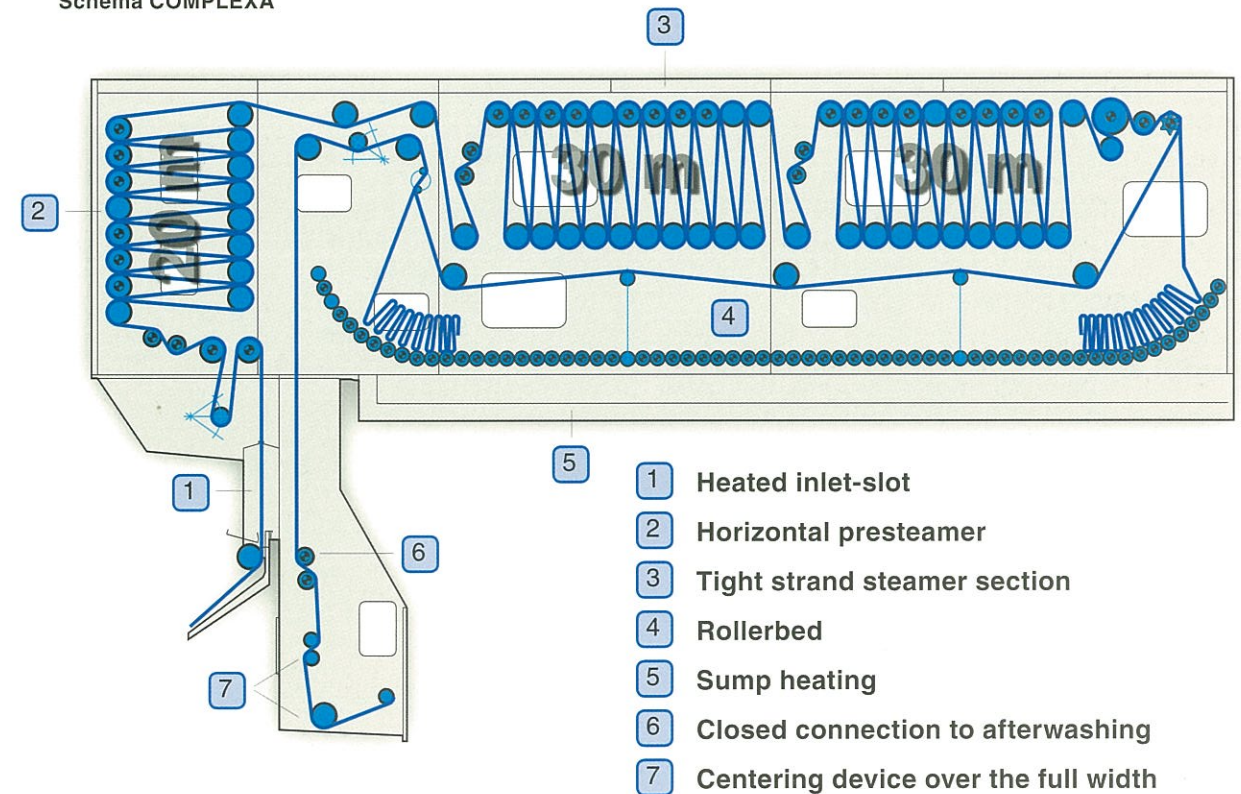

DIPSAT

Perfect Chemical Application

4

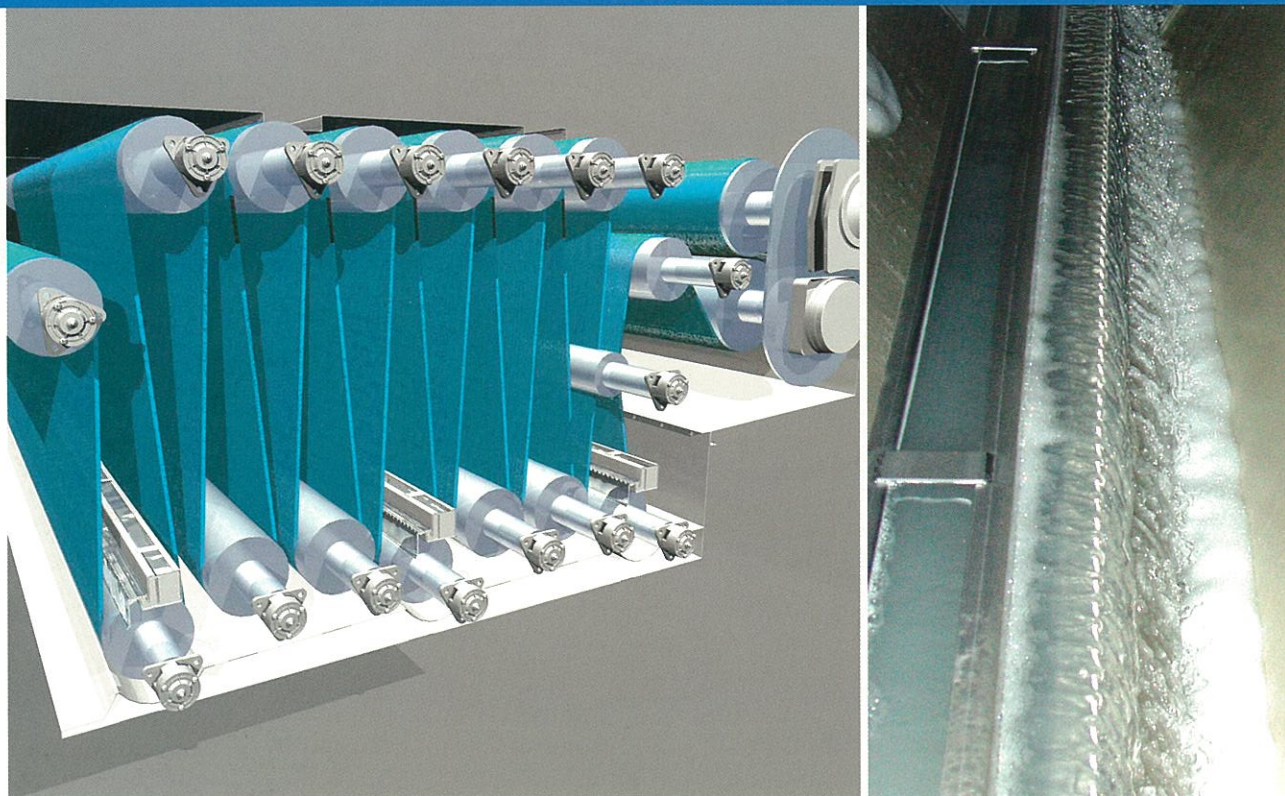

Advantages

- Liquor pick up from 90 to 130%
- Excellent liquor exchange and penetration to the core of the fibre
- No surface reaction or cloudiness in the steamer
No titration necessary because of fast bath exchange
- exchange
Minimized fibre damage

Successful and economical pretreatment

- Combines the advantages of high humidity application with those of a conventional impregnation compartment without its disadvantages (liquor volume, etc.),
Therefore longer penetration time, chemicals are
- impregnated up to the core of the fibre
3 dipping troughs for even chemical application
- Even bleaching effects are guaranteed

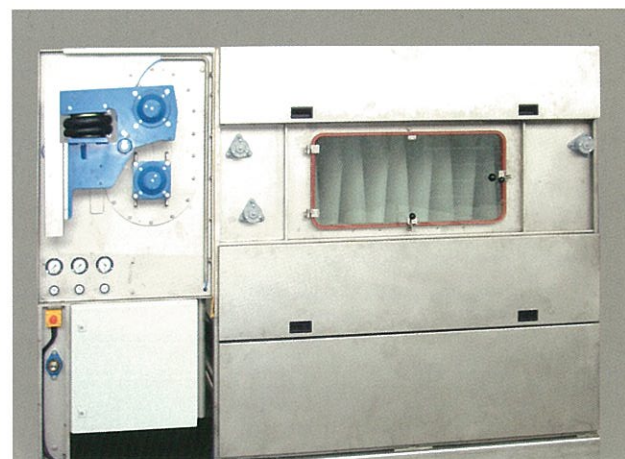

DIPSAT

Scheme

Liquor on the Move

5

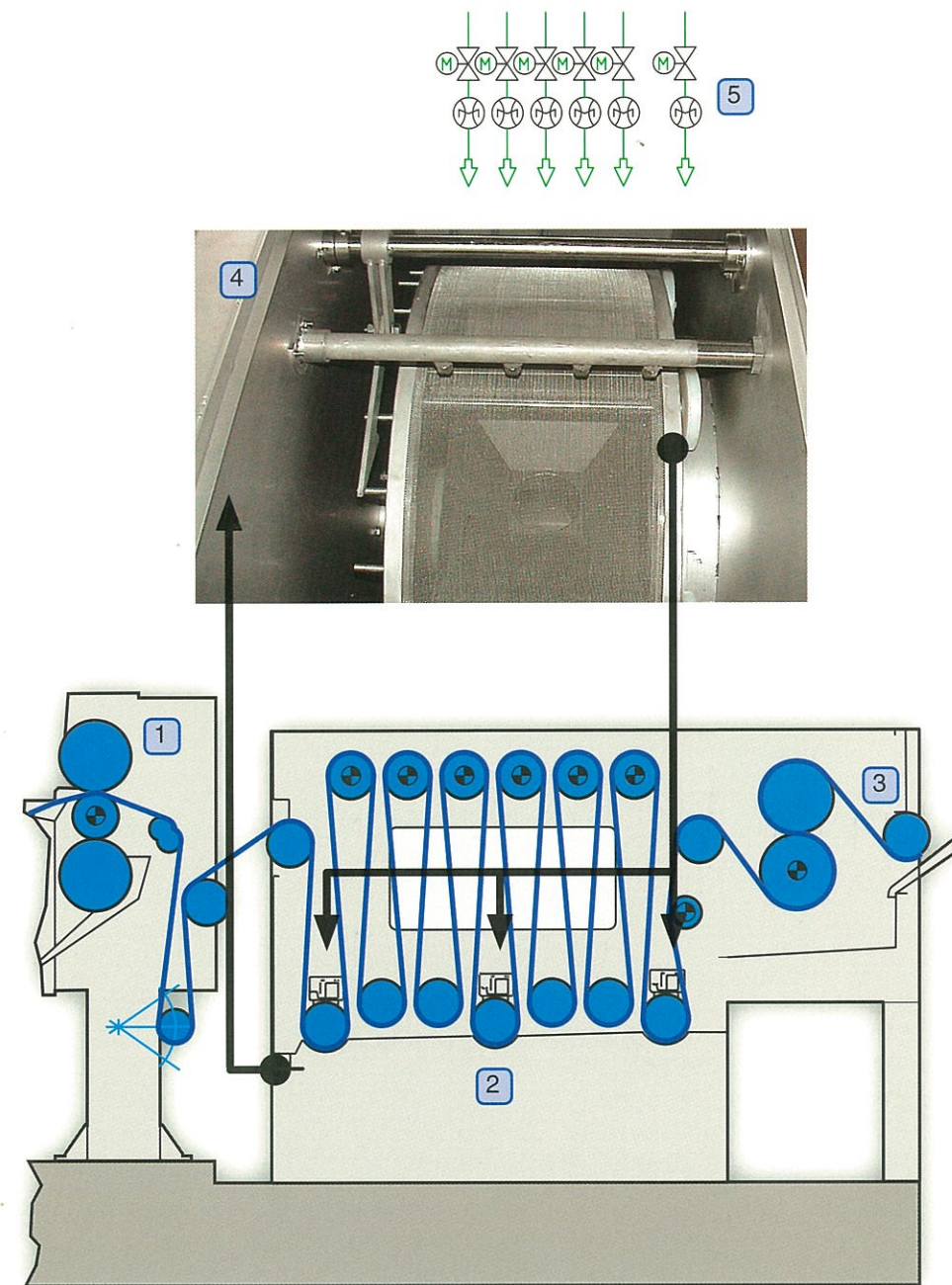

- 1 **Squeezer**
After squeezer 60% humidity
- 2 **Bath circulation**
- 3 **Pick up**
90-130% humidity

- 4 **Automatic filter SUPERCLEAN**
- 5 **Dosing by flowmeter**
Chemical dosing and water feeding into filter SUPERCLEAN

GOLLER - COMPLEXA

Core Components

6

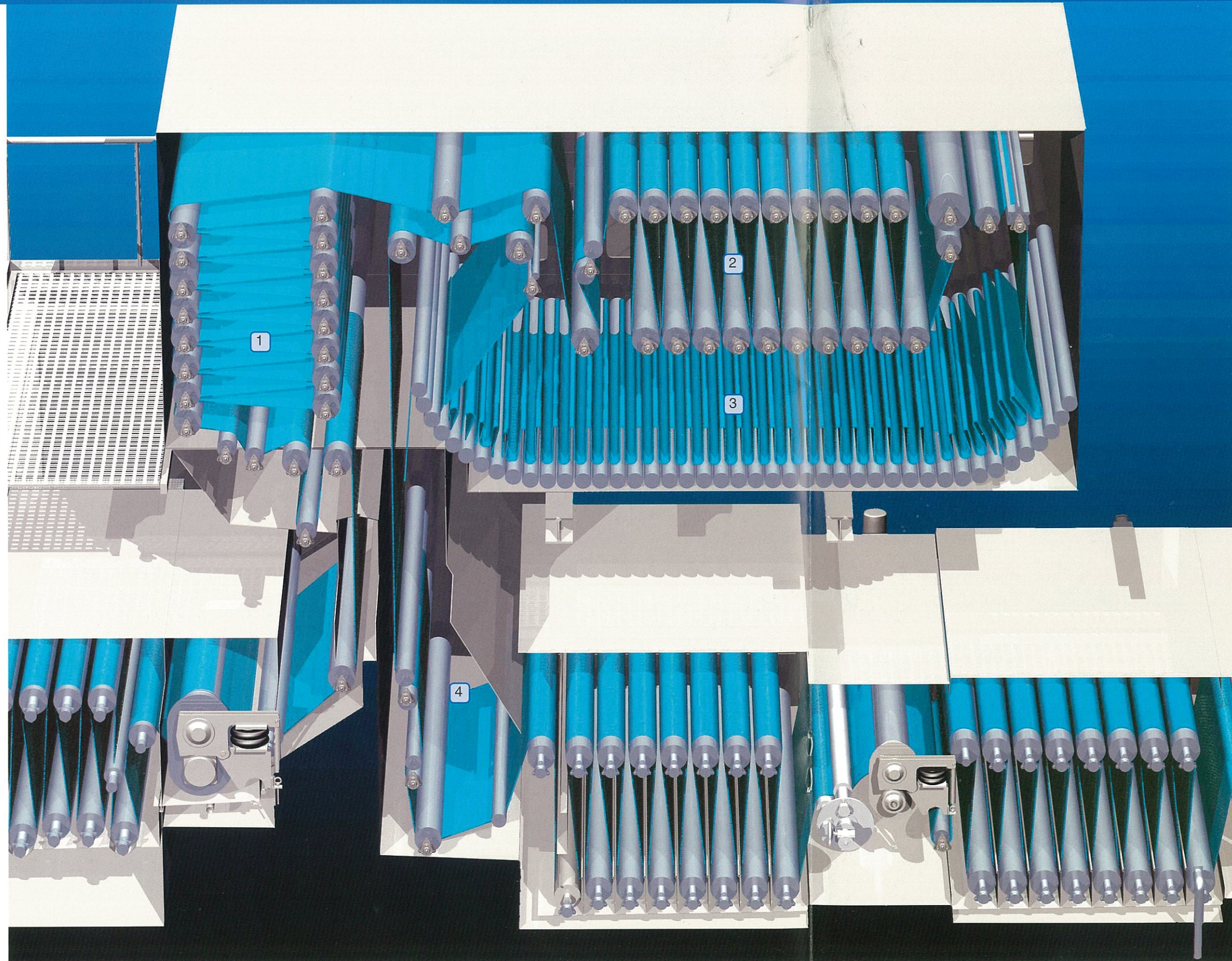

7

1 Horizontal steamer

- Complete absorption of the bleaching liquor
- Evenness of the liquor application
- Avoidance of dripping and creation of stripes
- Counter-current fabric/liquor
- Formation of liquor nips at the deflection point (penetration of the liquor into the fabric)
- Efficient and quick heating of the fabric

2 Vertical steamer

- Dwelling zone in tight-strand fabric guiding, therefore avoidance of formation of creases and cross marks during plaiting
- Heated steamer roof
- Short loop plaiter for exact fabric package formation
- Lowest fabric tension by frequency regulated additional drives of the upper guide rollers
- Fabric breakage surveillance

3 Rollerbed and bypass

- Recipe controlled fabric filling and dwelling times
- Careful fabric take-off from the upper part of the fabric package
- Exact fabric take-off by sensor rollers
- Overfilling-safety device for the rollerbed
- Program controlled change from plaited to tight strand – non stop
- Ideal steam condition and temperature distribution through sump heating

4 Passage to the washing range

- Steam-sealed passage avoids pollution of the atmosphere
- No cooling of the fabric, no condensation of the dissolved impurities
- Stress free opening and centering of the fabric by swivelling centering device
- Guaranteed crease-free fabric entrance into the final washing

GOLLER - COMPLEXA

Components

8

Fabric plate down

- Controlled package formation
- Short loop fabric plating
- PLC controlled reaction time



Fabric pullout

- Sensor roller for automatic synchronisation with following washing range
- Safety device to avoid rollerbed overfilling
- Precise fabric pullout



Expander combination

- Especially for weft elastic articles and stripe satin
- Fabric opening from both sides
- Adjustment possibility for perfect match with the fabric
- Driven by AC-gearmotor

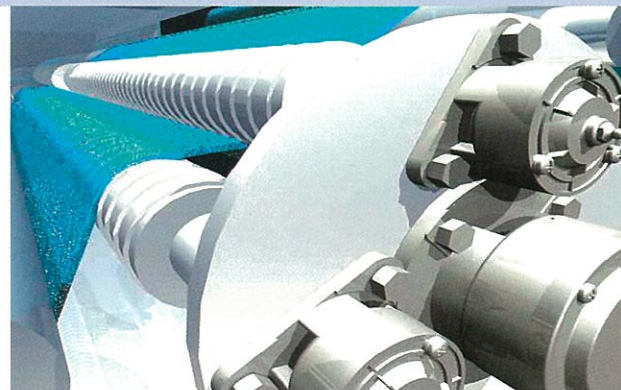

Process control

- Visualisation of the range
- Machine setting and survey of the operation parameters through PC
- Recipe administration for reproducible results
- Error list
- Protocol of machine conditions
- Remote control via modem
- Consumption data registration (optional)

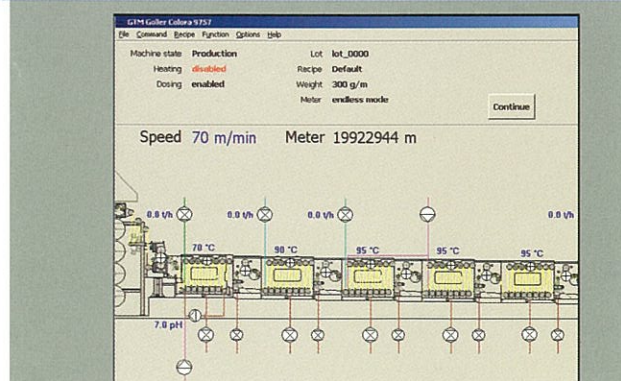

GOLLER - DESIZA

Perfect Desizing is the Key to Excellent Bleaching

9



DIPSAT IMPREGNATION

- Low liquor volume with quick bath renewal
No accumulation of impurities and enzyme killers
- Single component dosing also in desizing
Recipe controlled

S-WRAP SQUEEZER

- Defined liquor with pick up above 100% results in excellent degree of desizing
Slip-free and crease-free fabric transport

GOLLER - COMPLEXA

Possible Set-Ups

10

Singeing and desizing range

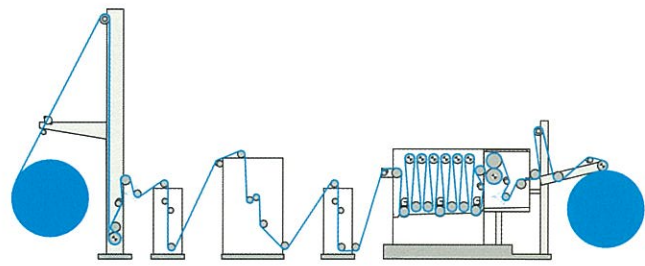

Scouring and bleaching range

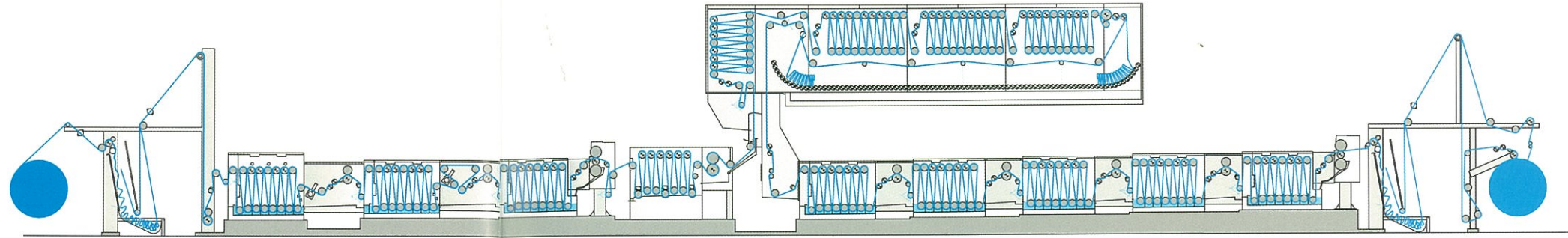

11

Two-step-bleaching range

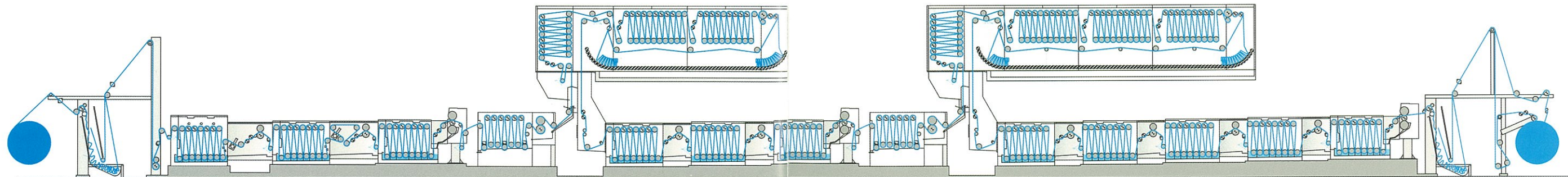

Woven and knitted fabrics

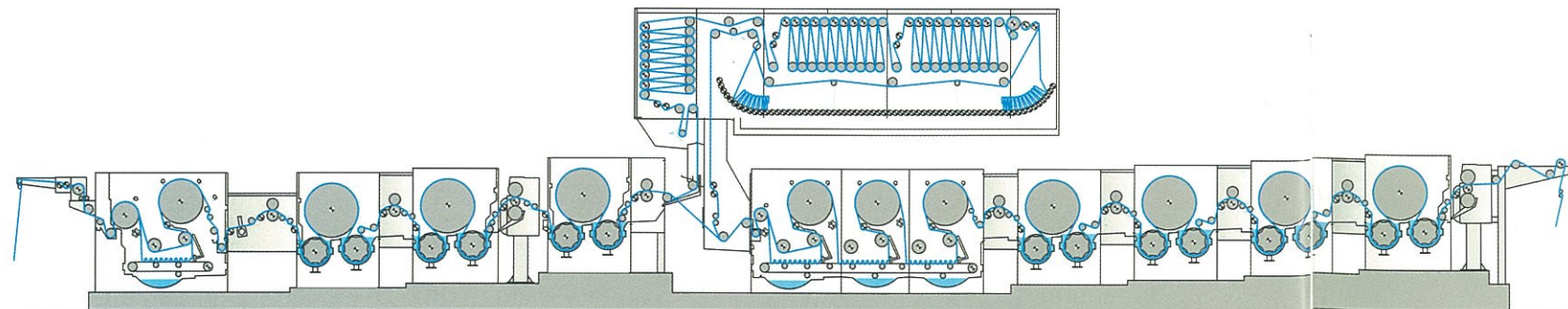



GOLLER Textilmaschinen GmbH. Headquarters in Schwarzenbach/Saale

For the sake of textile

we develop, manufacture and deliver wet finishing ranges for more than a hundred years to the worldwide market and are one of the most important producers in this market segment.

Focusing on the whole and detail

GOLLER can provide individually designed systems for continuous and efficient production processes. From desizing to end washing we offer a large scope of sophisticated and high-performance ranges.

Focusing on YOU

Due to the ongoing research and development as well as the constant contact with the textile industry, chemical suppliers and institutes you can rely on a wide knowledge.

Environmental consciousness is one of our top priorities

We care for a clean environment due to the economic use of dyestuffs, auxiliary agents, water and energy. Each drop of liquor, which is running through our machines will be returned environmentally friendly.

Let's talk together

There are 65 agents all over the world available for your individual requirements. Or contact us directly!

Goller Textilmaschinen GmbH

Am Hammeranger 1
95126 Schwarzenbach / Saale
GERMANY
Telephone +49.9284.932-0
Fax +49.9284.932-102
info@goller.de
www.goller.de

GOLLER Textilmaschinen (HK) Limited

8/F., 22-28 Cheung Tat Road
Tsing Yi
HONG KONG
Telephone +852.2449.9280
Fax +852.2449.9638
info@goller-hk.com
www.goller.de

Marketed by



A.T.E. ENTERPRISES PRIVATE LIMITED

Bhagwati House, A-19, CTS No 689,
Veera Desai Road,
Andheri (West), Mumbai-400 053, India
Tel.: +91-22-6676 6100 Fax.: +91-22-2673 2446
E-mail: teg@ateindia.com Website: www.ateindia.com

