

MAN-MADE FIBERS

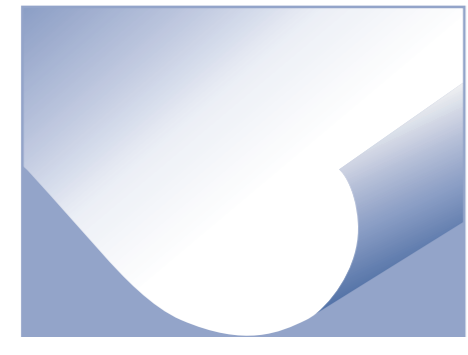

NONWOVENS

TRÜTZSCHLER
NONWOVENS

Fleissner Smoothing/Calibrating



Line pressure:	50 - 600 N/cm
Output:	< 100 m/min
Working width:	7,000 mm

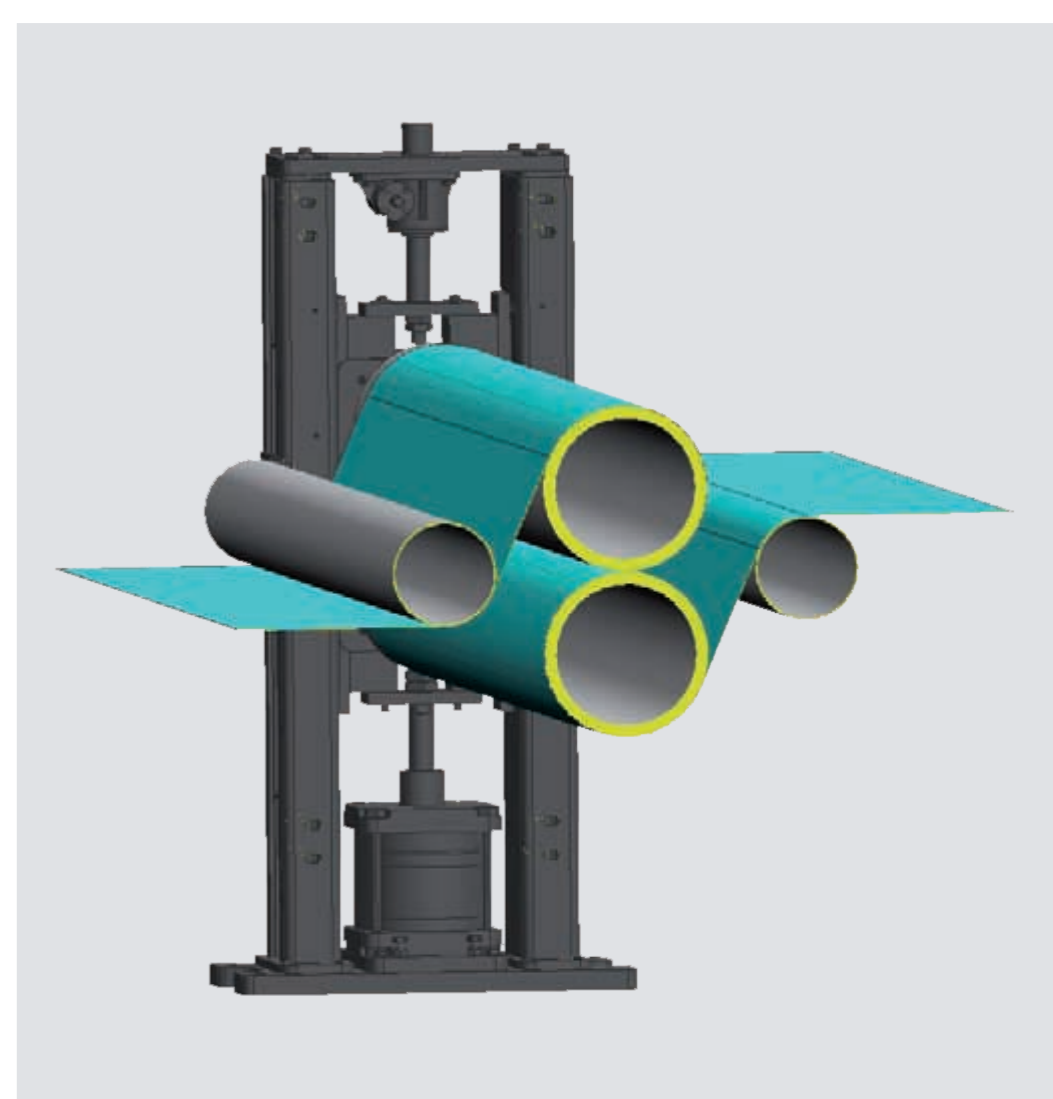
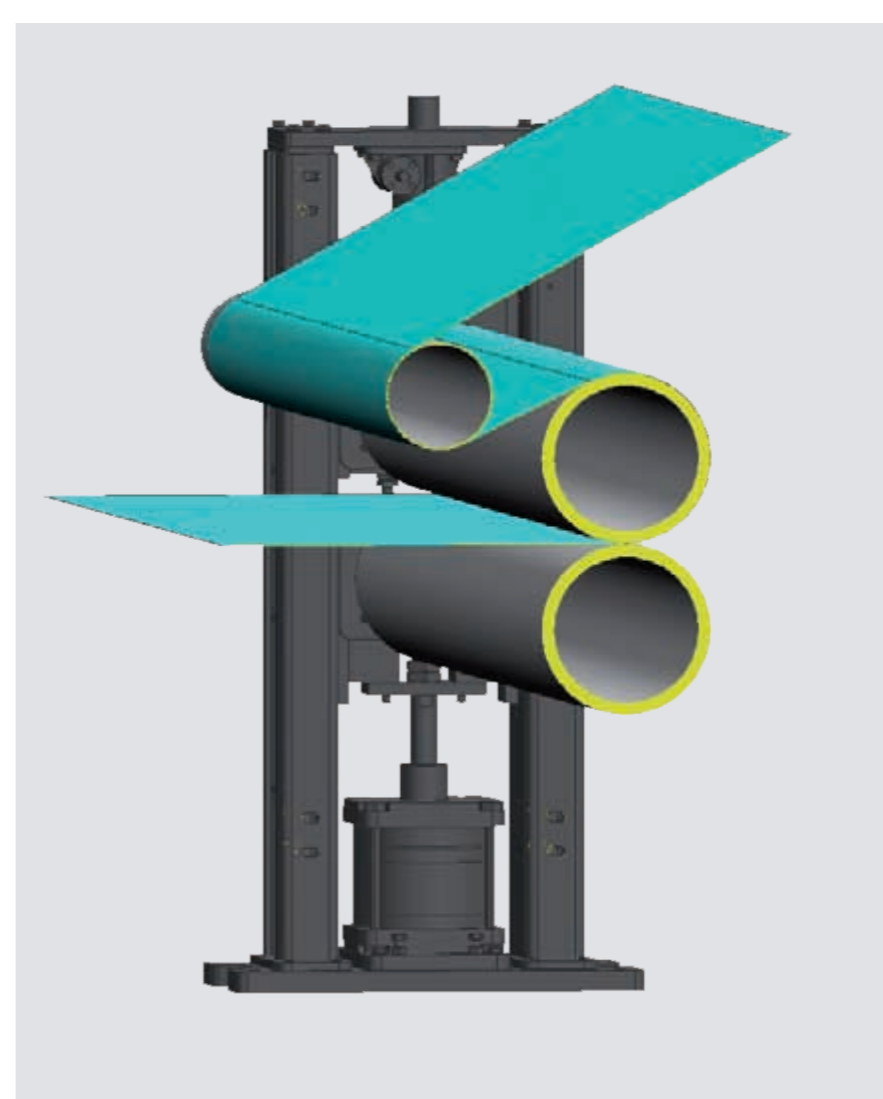
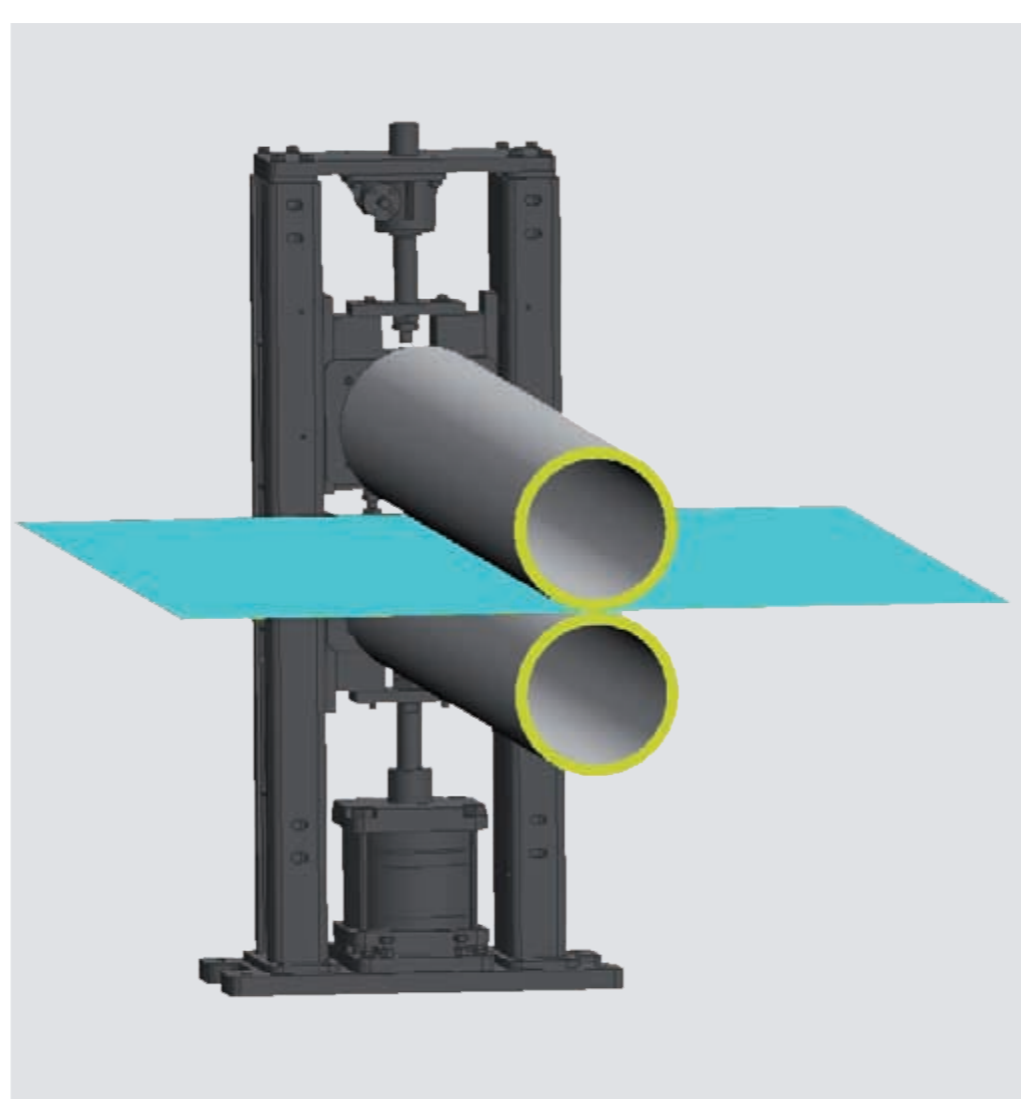
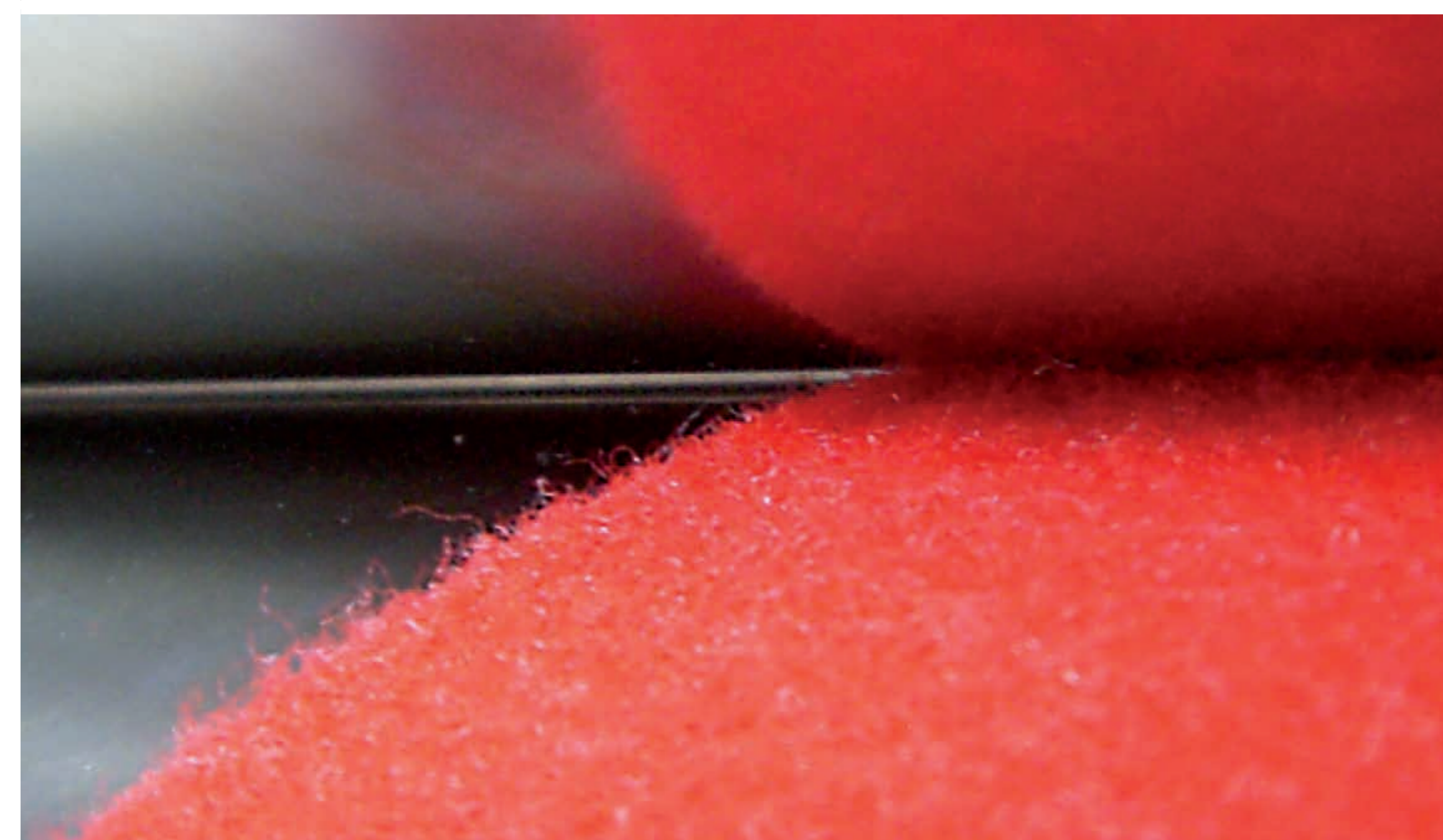

Flexible treatment with different material flow

Surface Treatment – Uniform line pressure,
together with a uniform gap width, ensures
optimal results

www.truetzschler.com

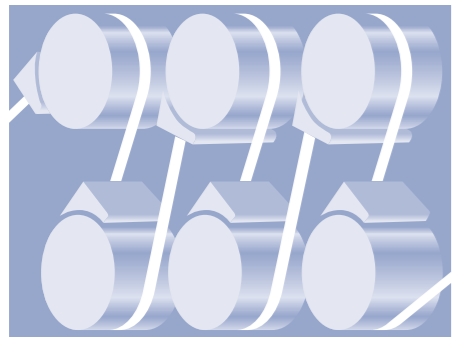

MAN-MADE FIBERS

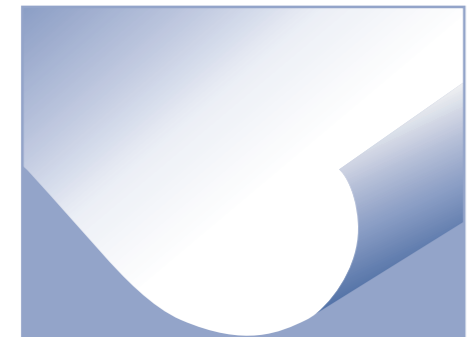

NONWOVENS

TRÜTZSCHLER
NONWOVENS

Fleissner Hydroentangling



Working width: 500 - 5,000 mm

Speed: < 500 m/min
(spunbond web up to 1,000 m/min)

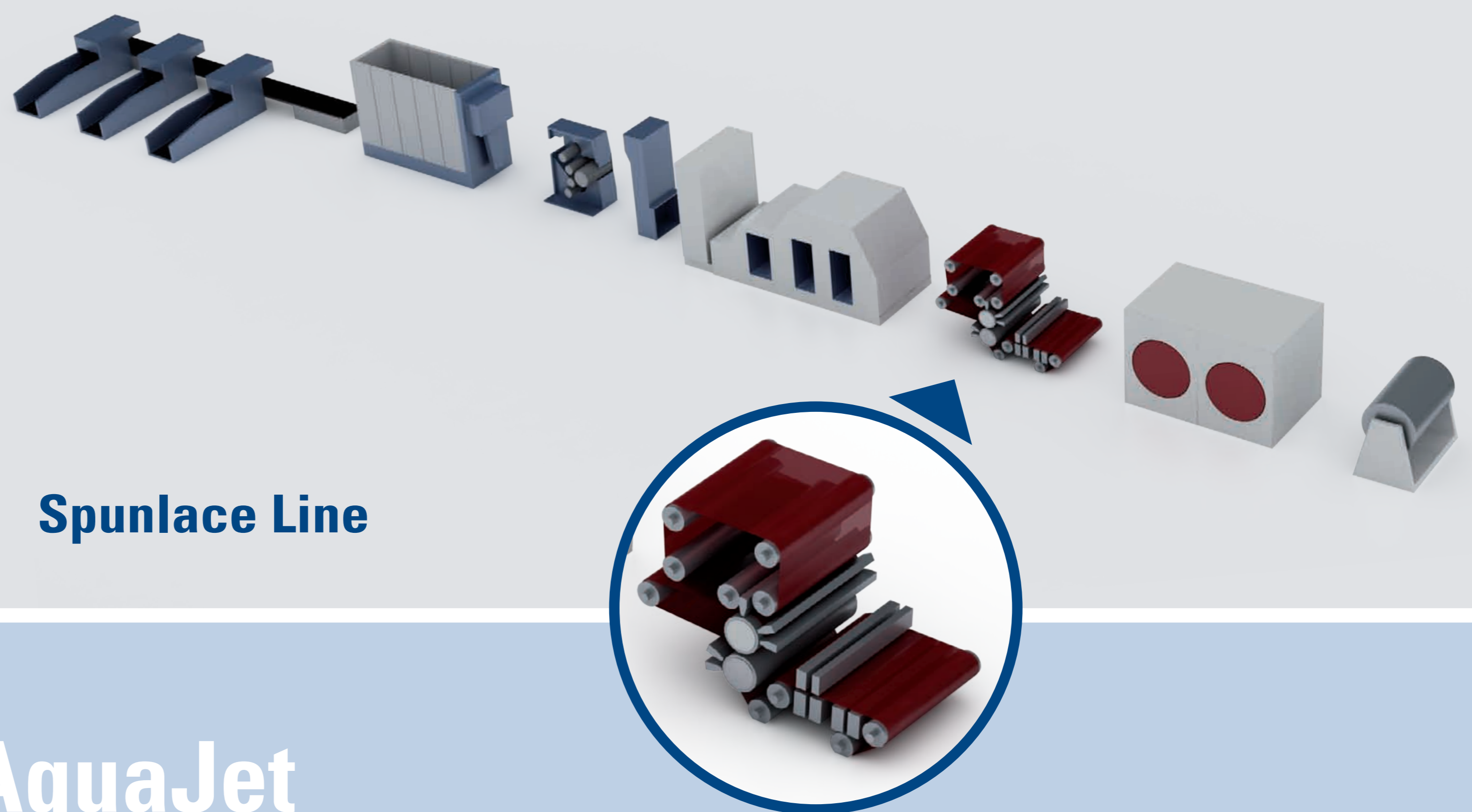
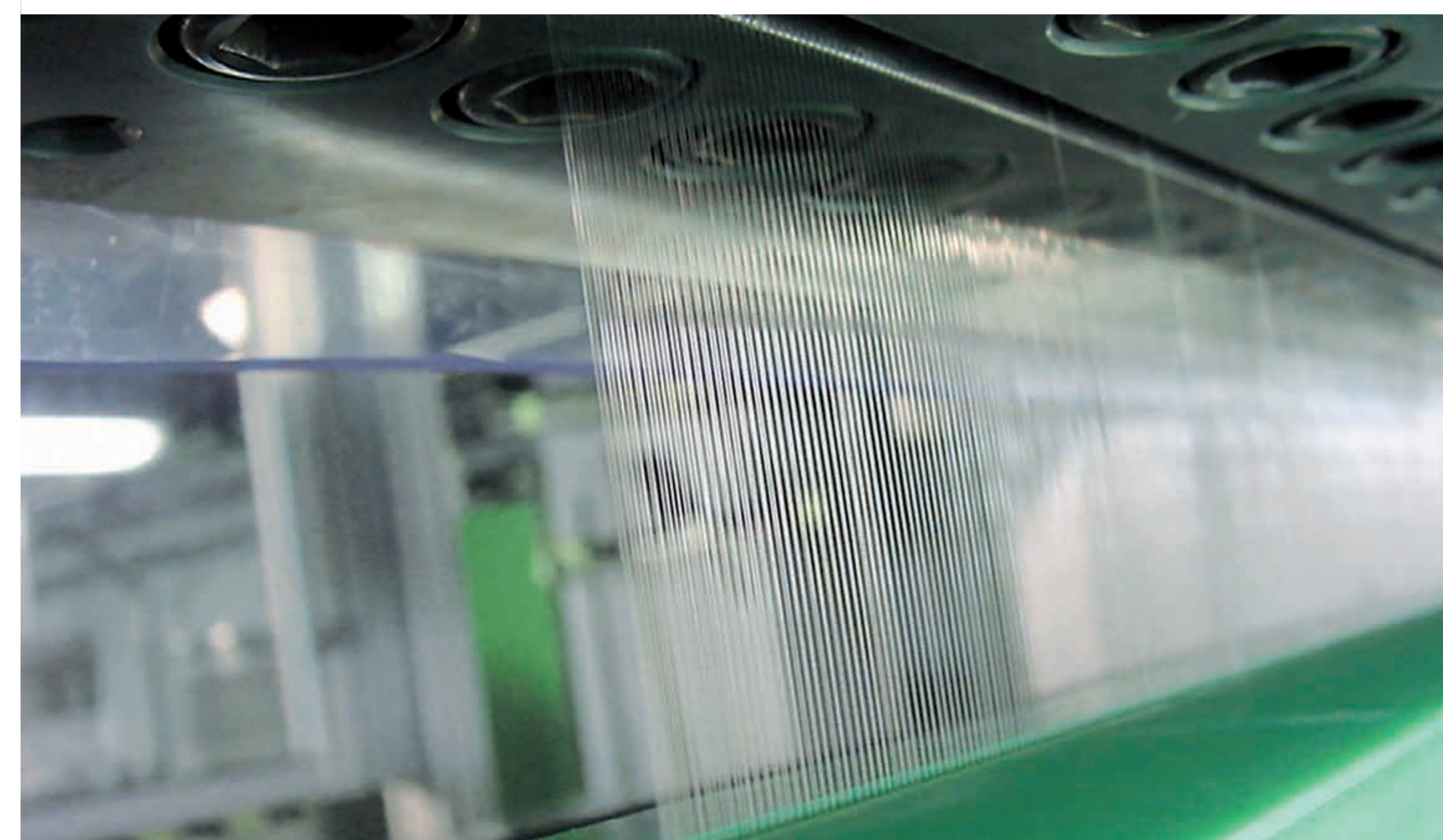

Spunlace Line

Aqua Power – Fleissner AquaJet
Hydroentanglement creates a wide variety
of products in exceptional high quality

www.truetzschler.com

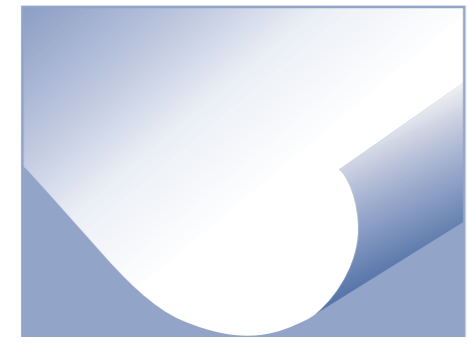
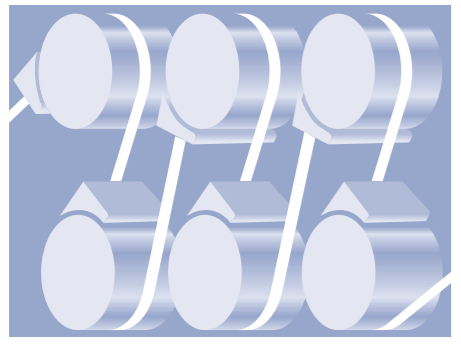

TRÜTZSCHLER
NONWOVENS

MAN-MADE FIBERS NONWOVENS

Fleissner Drying



Output: < 1,500 m/min

Working width: < 7,000 mm

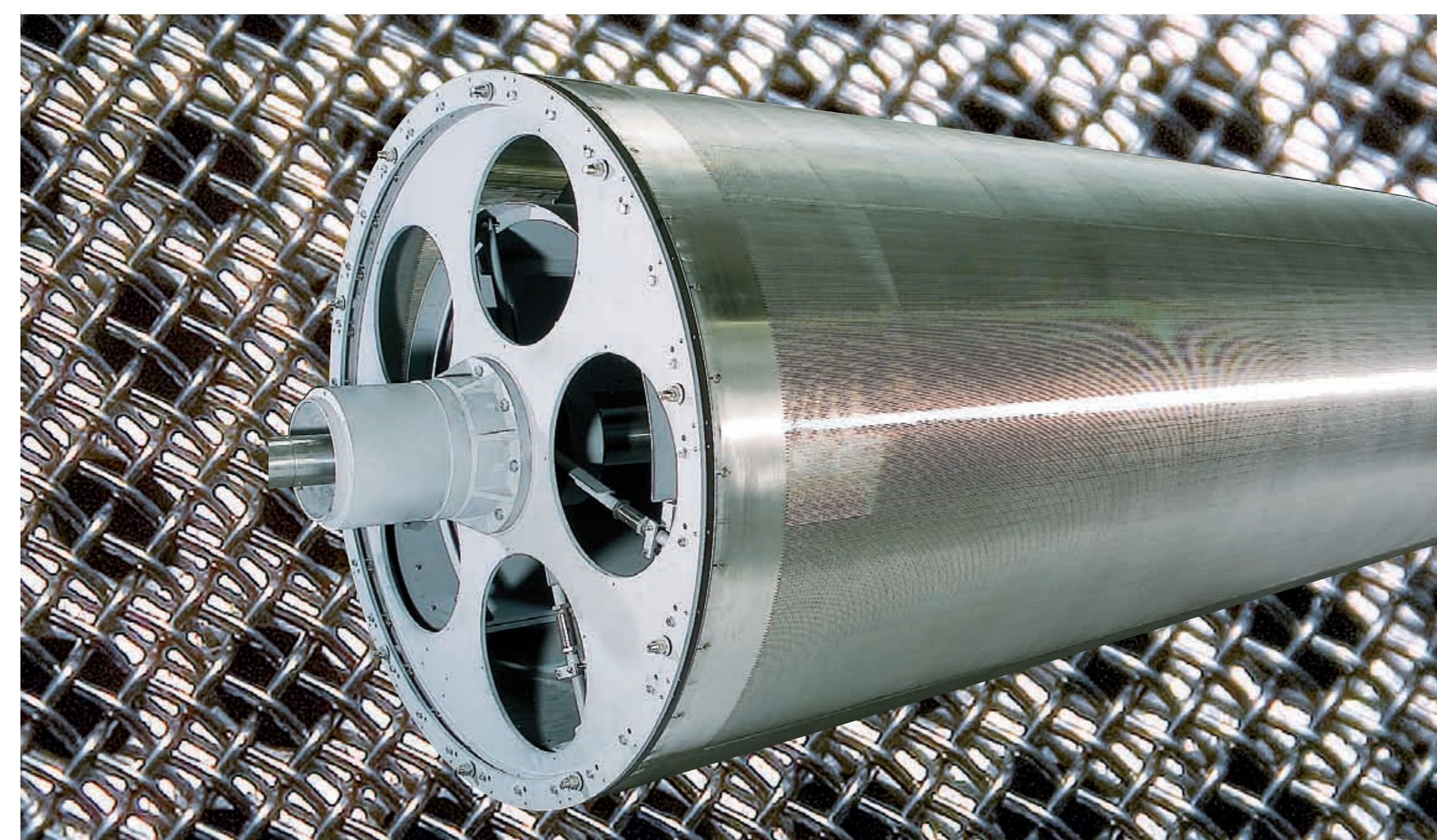

Thermobonding Line

**High-Speed Drying –
Optimal drum surfaces for perfect air
guidance and drying**

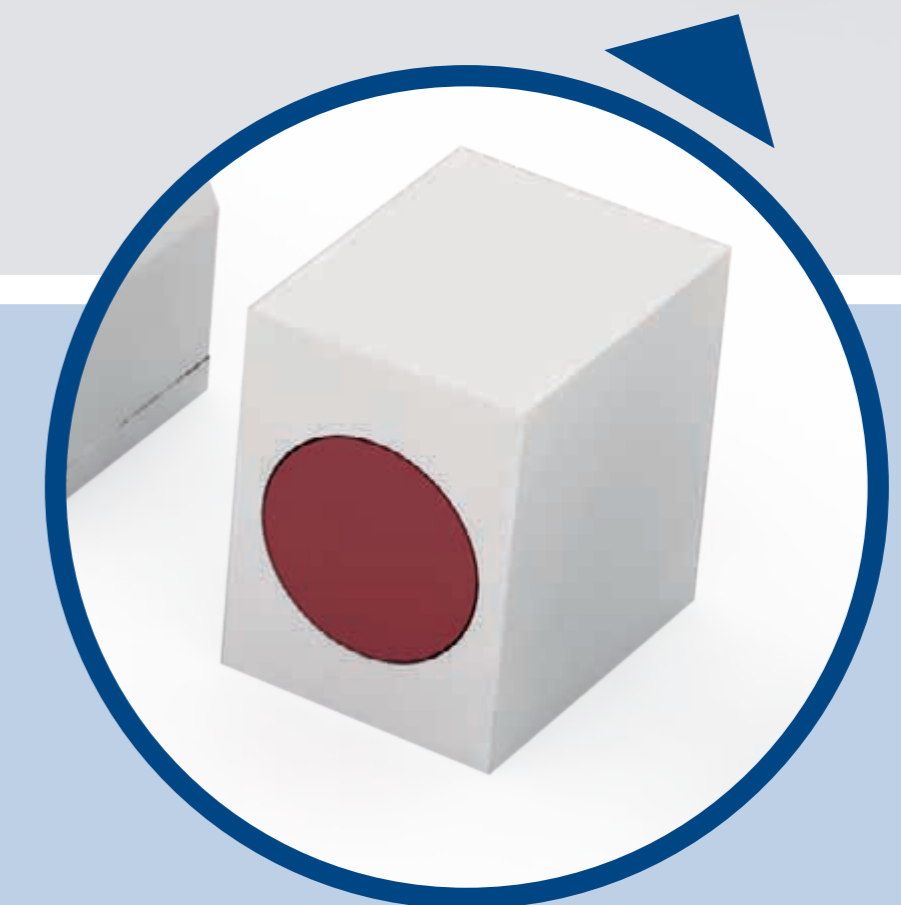

www.truetzschler.com

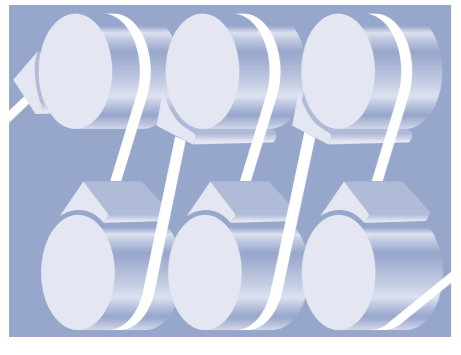

MAN-MADE FIBERS



NONWOVENS

TRÜTZSCHLER
NONWOVENS

Fleissner Belt Oven

Web weight: <math>< 10,000 \text{ g/m}^2</math>

Working width: <math>< 7,000 \text{ mm}</math>

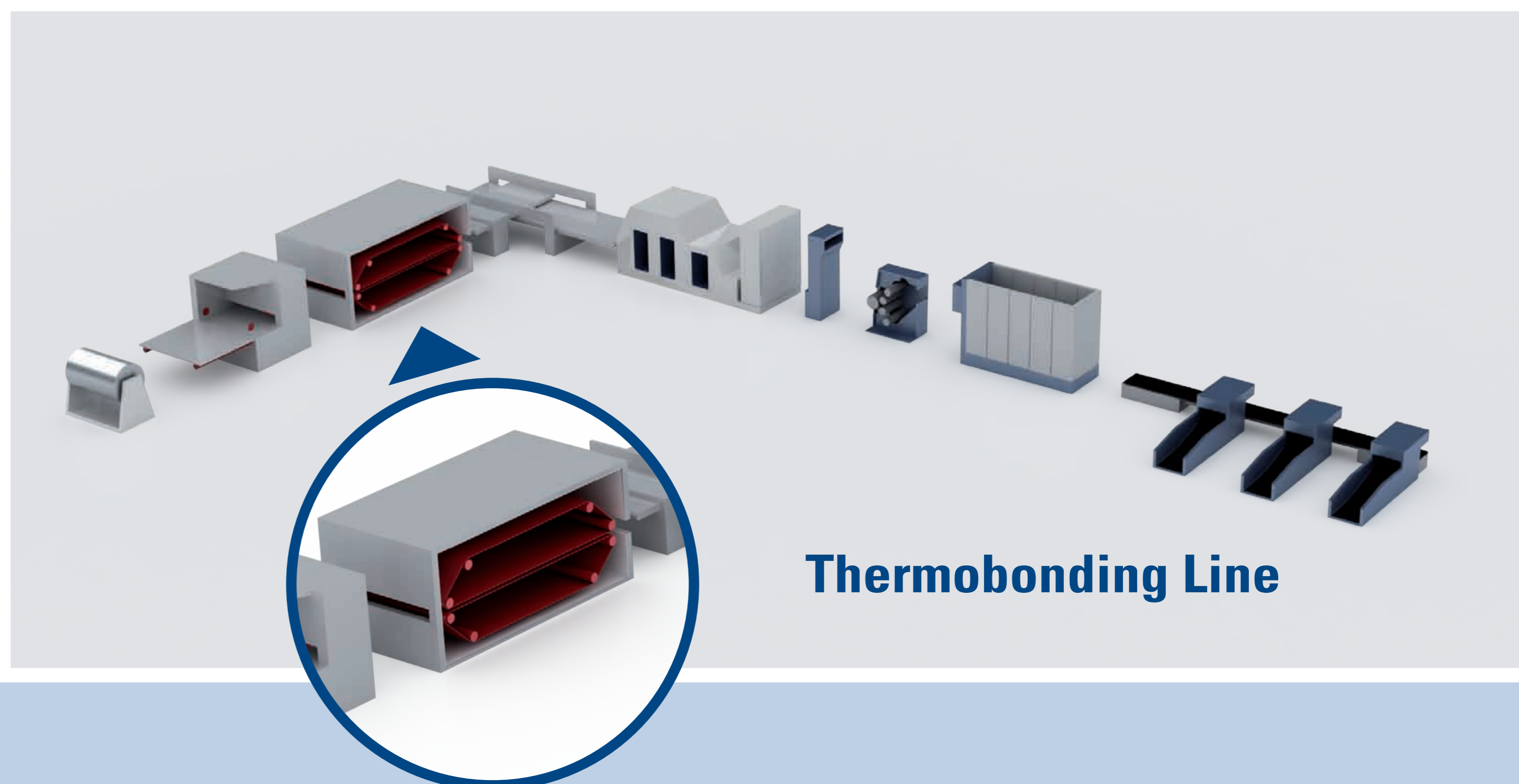
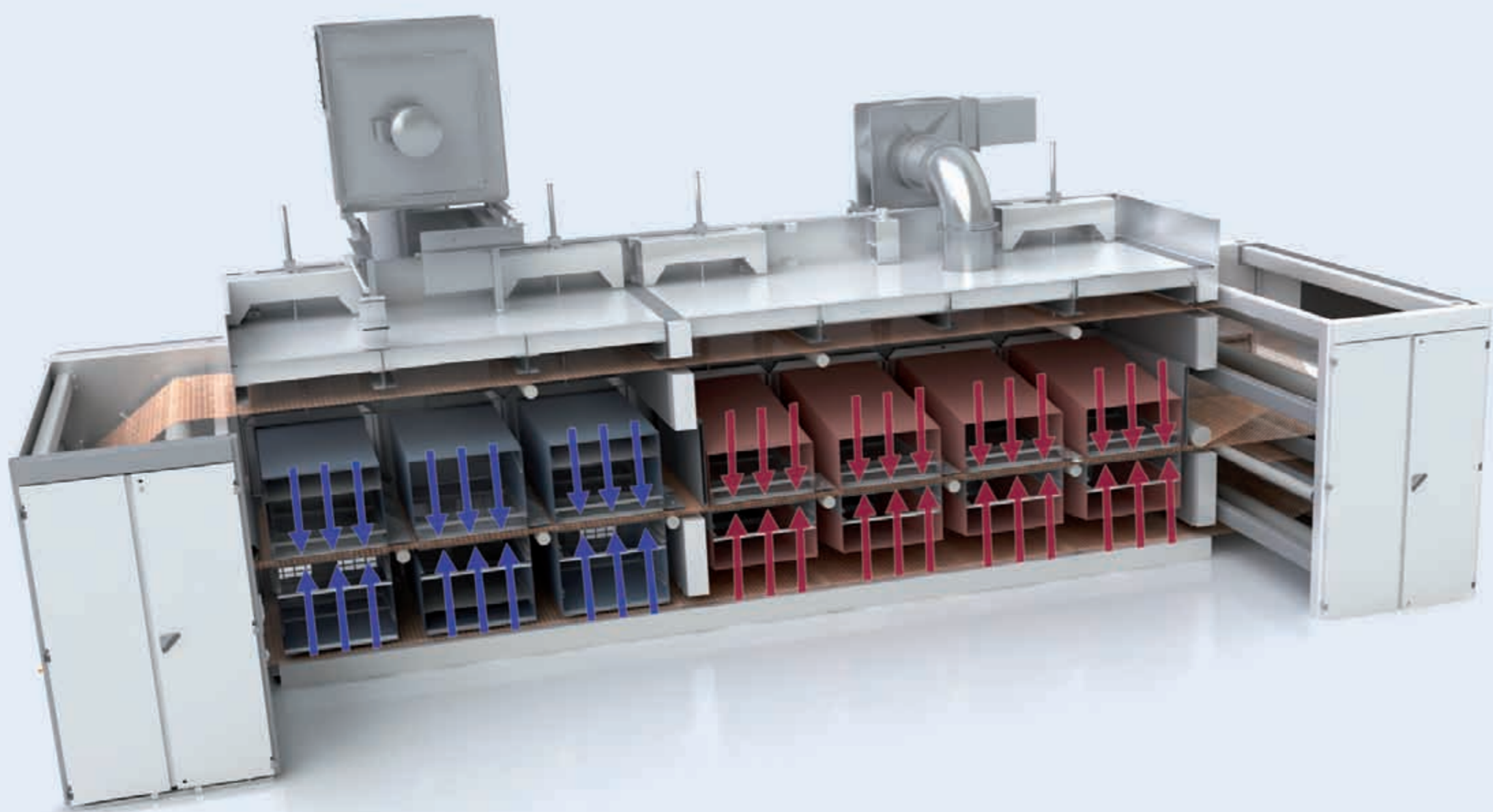

Thermobonding Line

**Voluminous Highloft Products –
Produced on the new
Fleissner Belt Oven design**

www.truetzschler.com

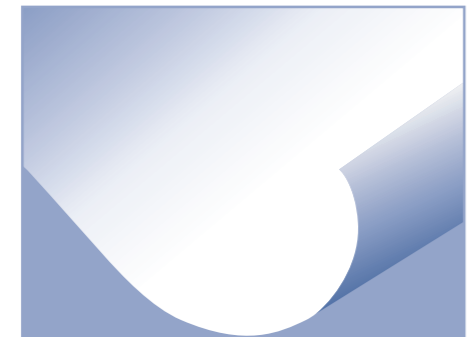
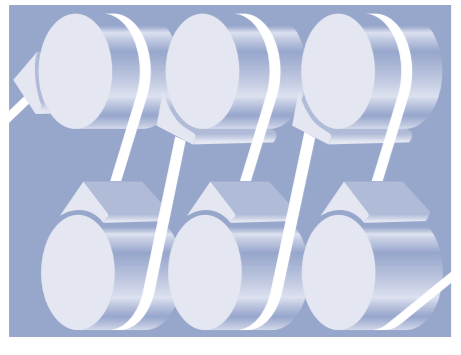

TRÜTZSCHLER
NONWOVENS

MAN-MADE FIBERS NONWOVENS

Fleissner AquaJet Family

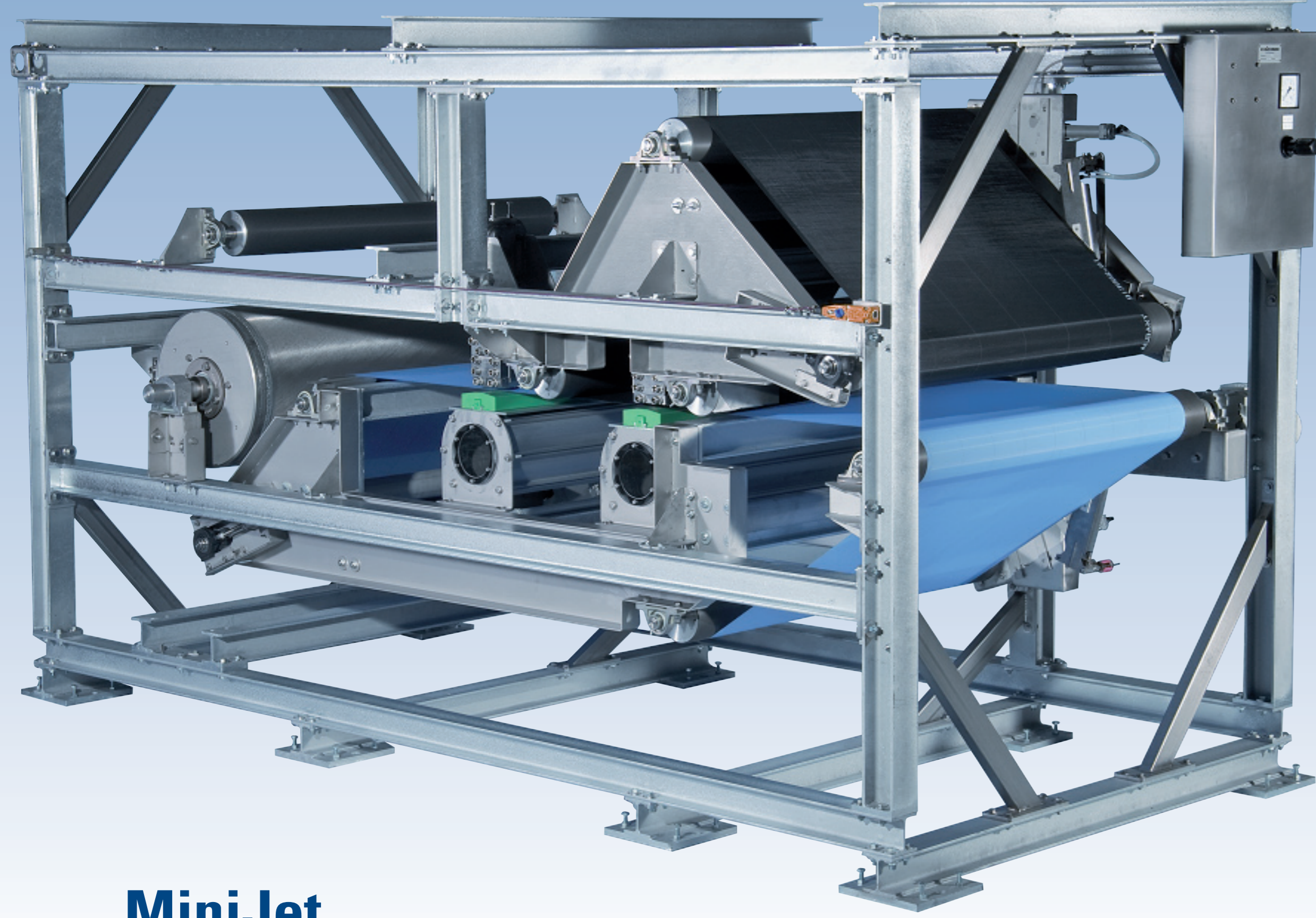

MiniJet



LeanJet

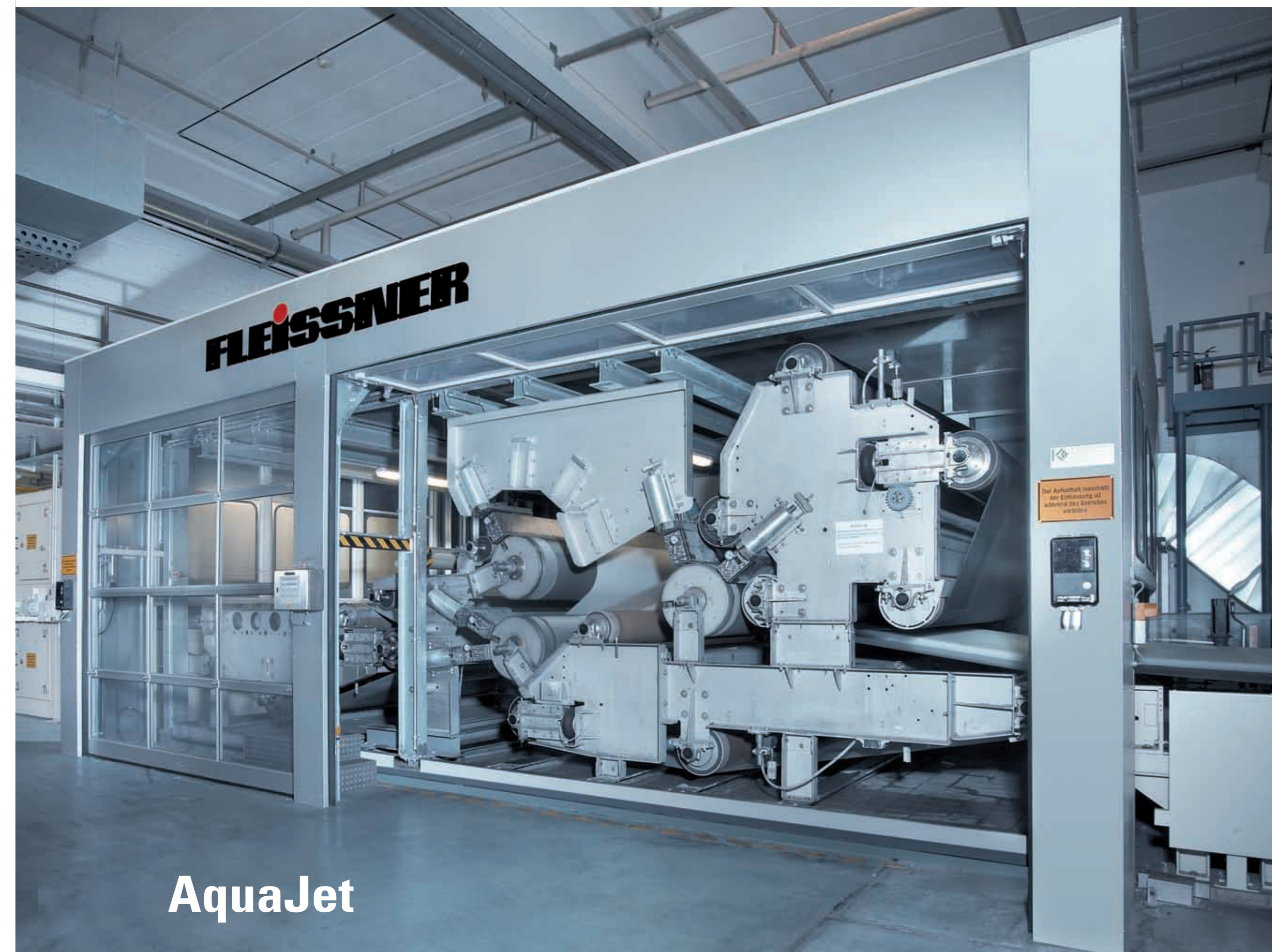

AquaJet



Jumbo AquaJet

Working width: 500 - 5,000 mm

Speed: < 500 m/min
(spunbond web up to 1,000 m/min)

**Tailor-Made – With the Fleissner
AquaJet Family you will find customized
solutions for your needs**

www.truetzschler.com

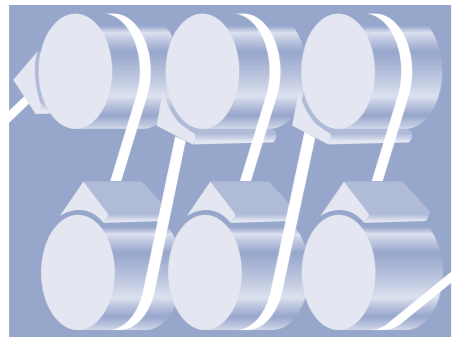

MAN-MADE FIBERS

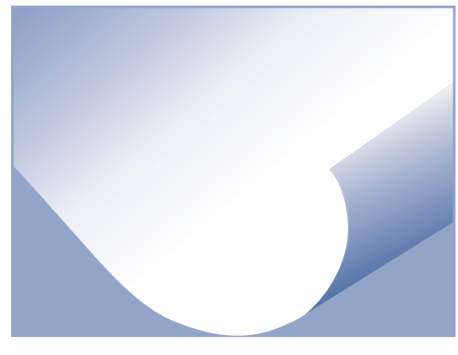

NONWOVENS

TRÜTZSCHLER
NONWOVENS

Latex Free Backing for Artificial Grass

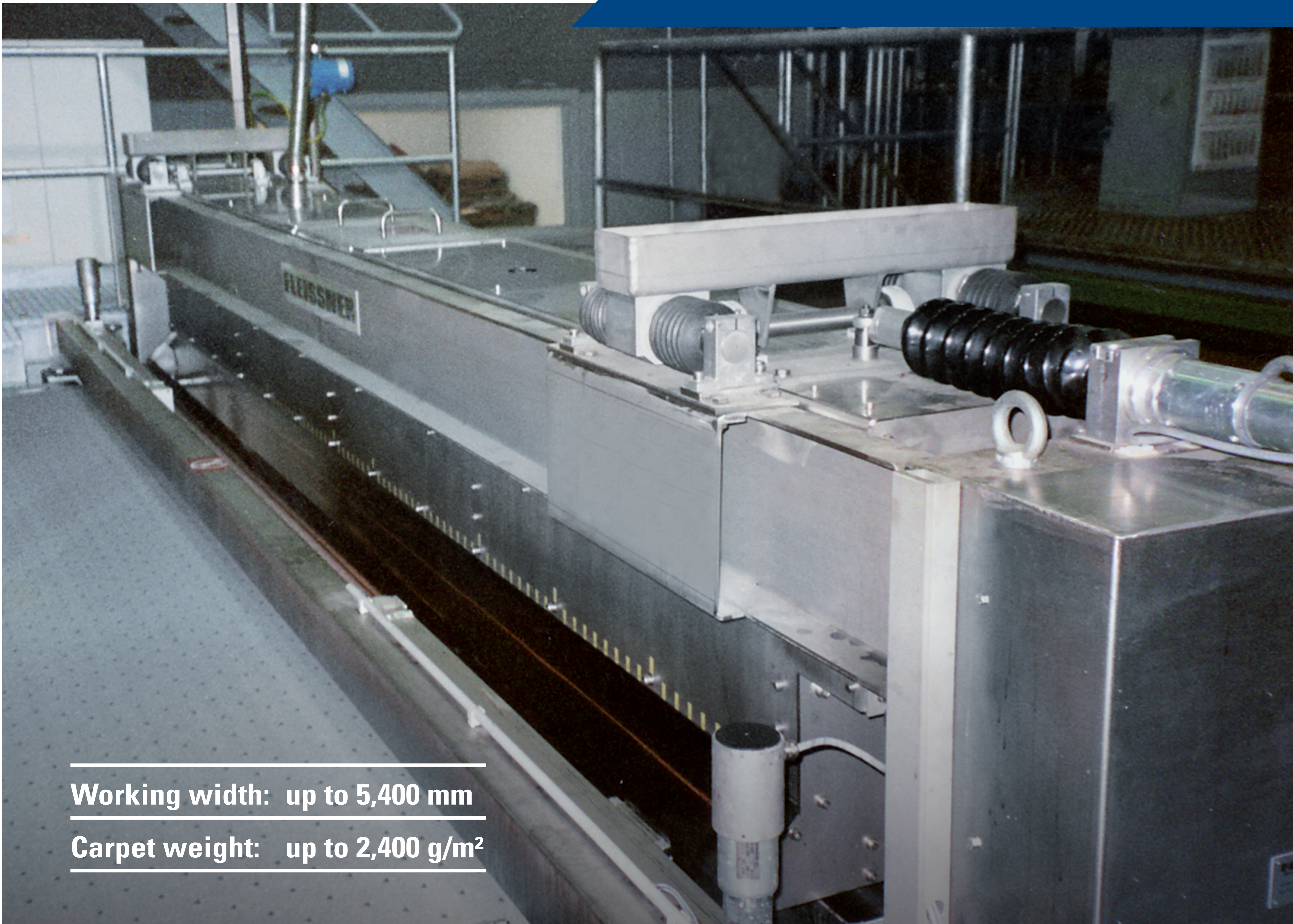

Working width: up to 5,400 mm

Carpet weight: up to 2,400 g/m²

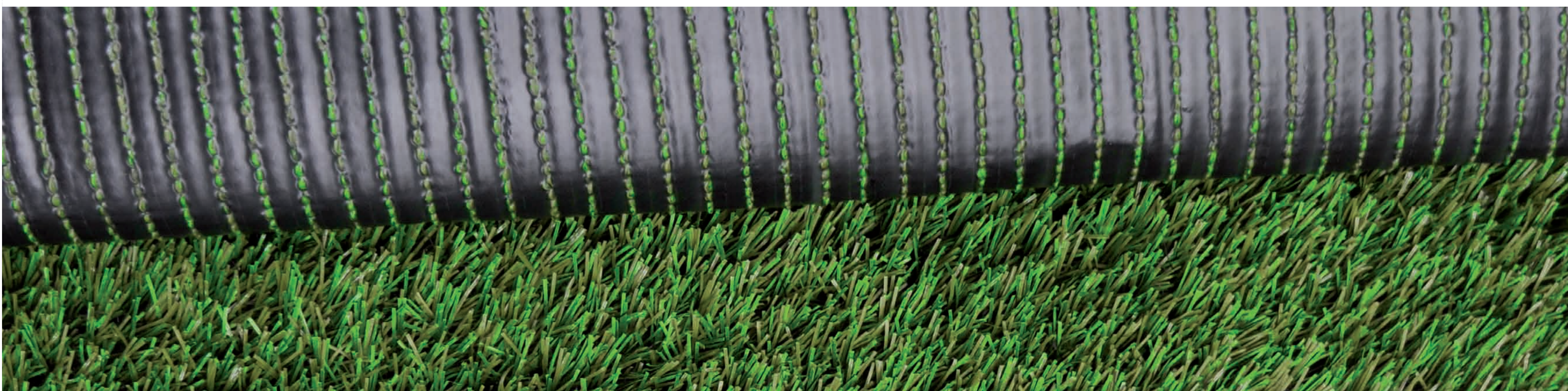

Recyclability – The Fleissner hotmelt application ensures environmental products by replacing latex

www.truetzschler.com